

5105H/5106H SERIES

2.00mm PITCH WIRE TO WIRE CONNECTOR

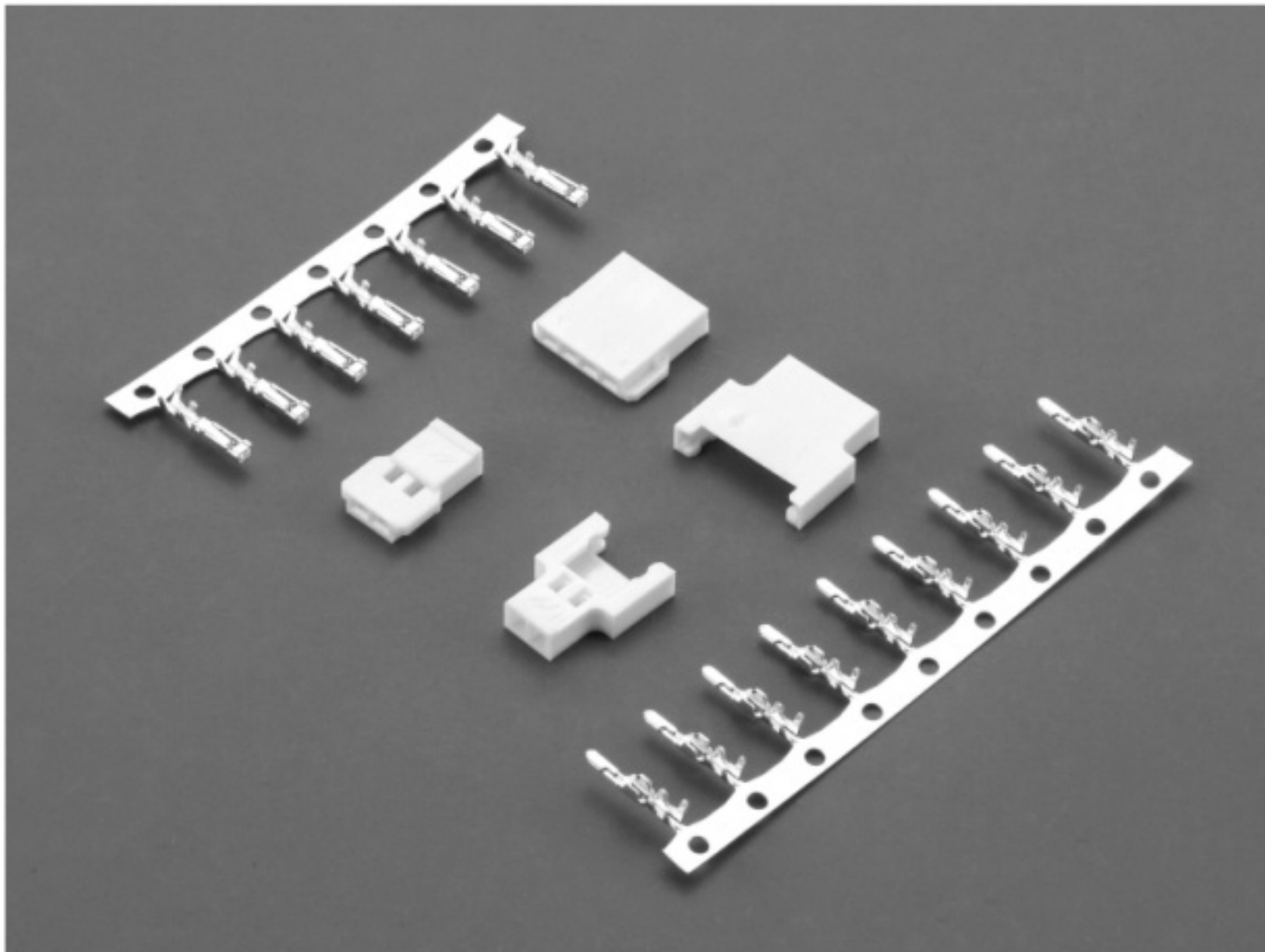

Specifications

Current Rating: 2A AC,DC

Voltage Rating: 125V AC,DC

Temperature Range: -25°C~+85°C

Contact Resistance: 20mΩ Max.

Insulation Resistance: 1000 MΩ Min.

Withstanding Voltage: 500V AC/minute

Applicable wire: AWG#24-#28

Assembly layout

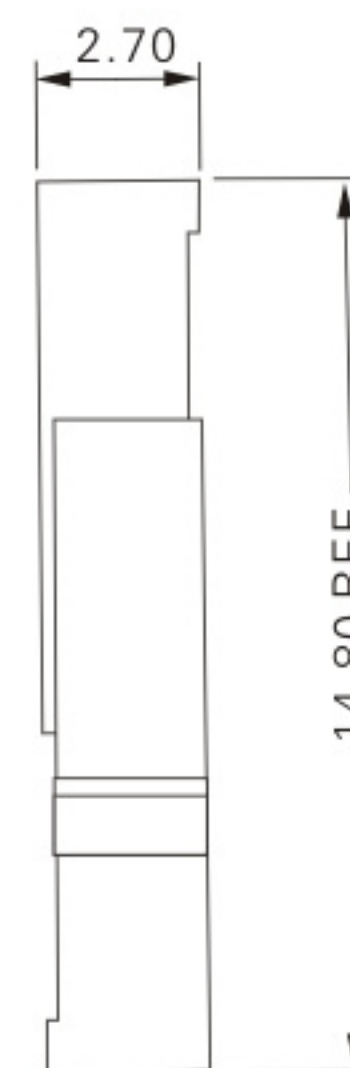
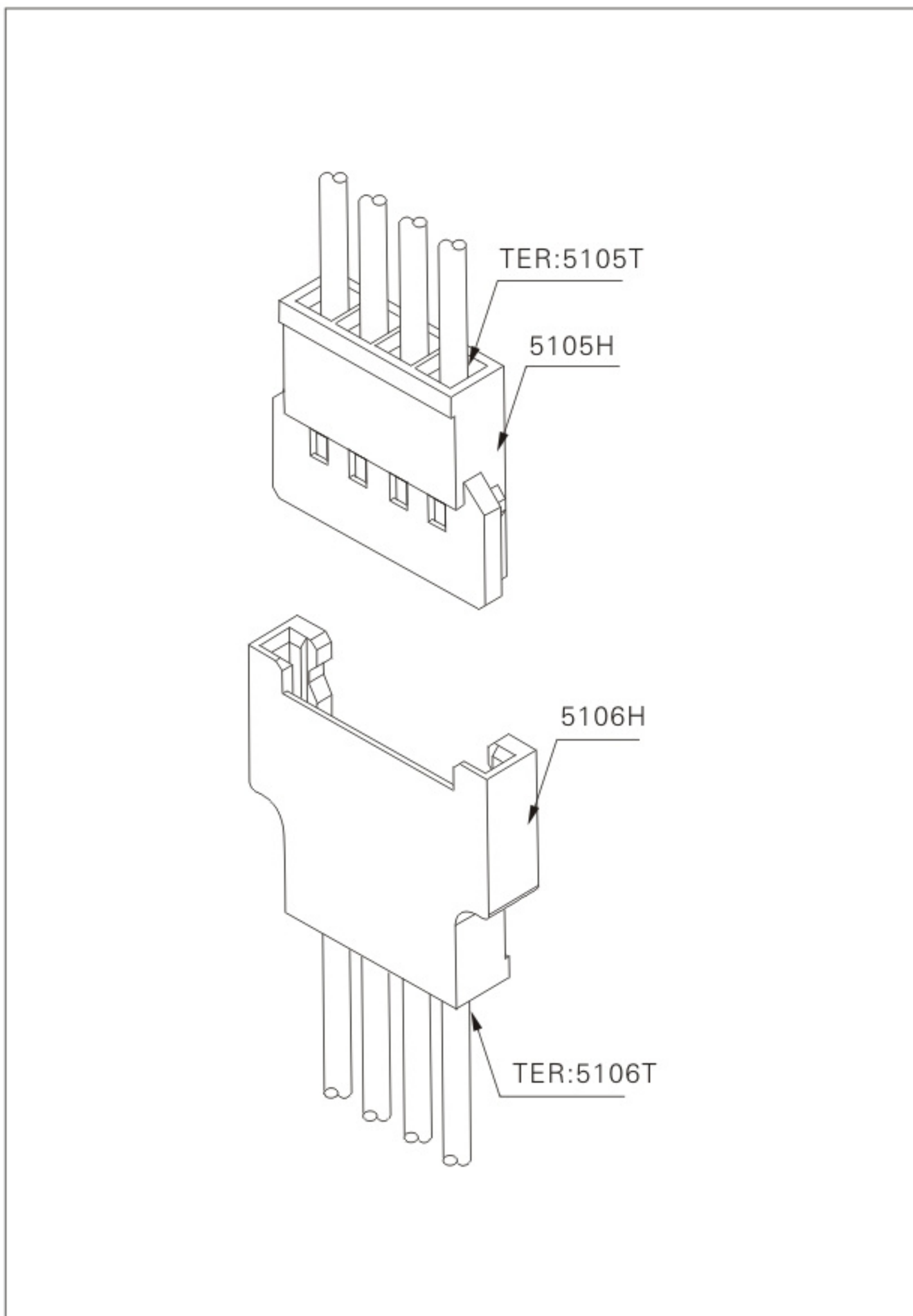

5105-T (2.00mm pitch crimp terminal)

Reference Informations:

*Used in 5105H series Housing

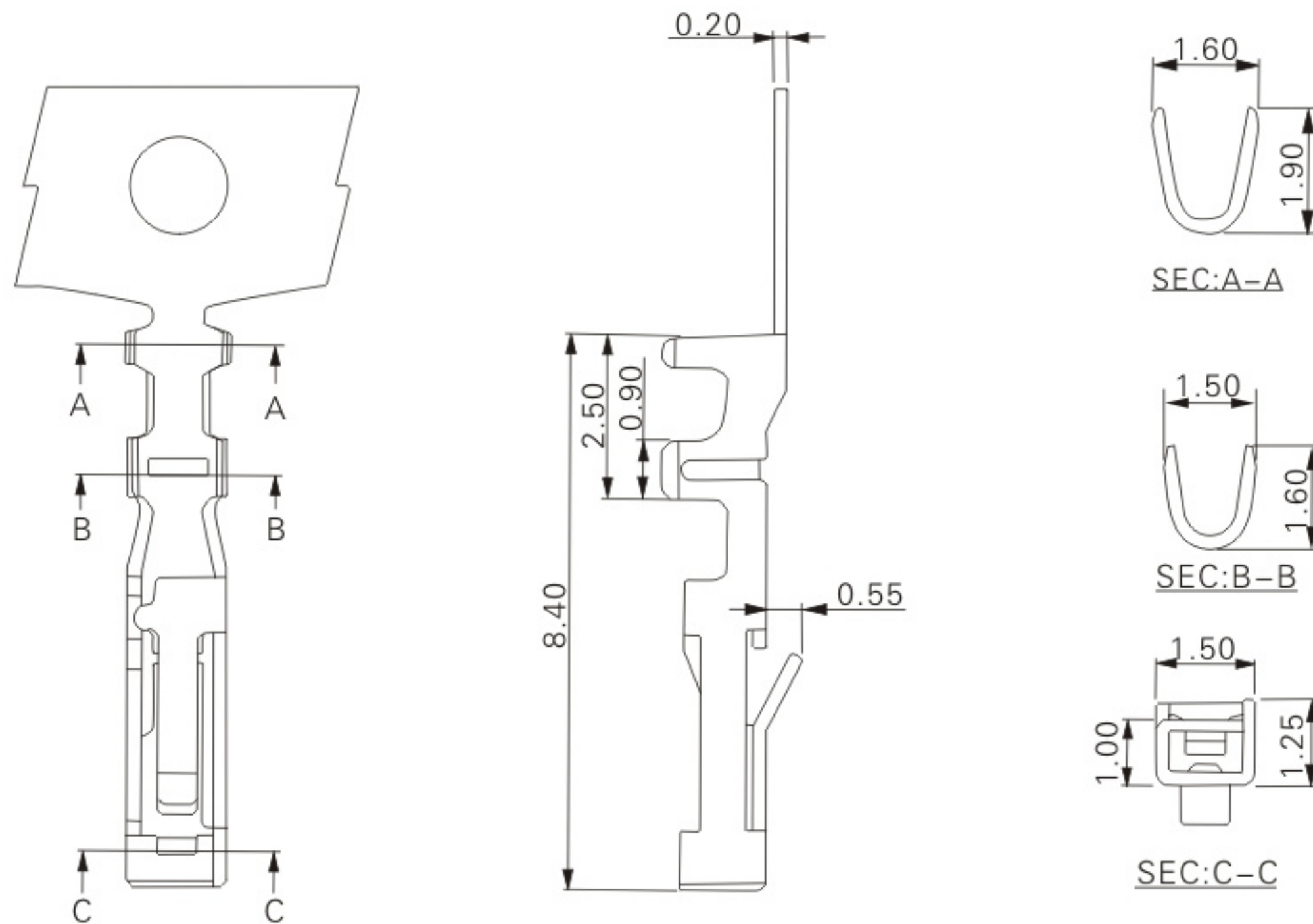

Ordering Information & Specifications

Unit: mm

Part No.	Wire Range	Insulation O.D.	Material	Finish	Qty/reel
5105P	AWG#24-#28	1.40mm(max)	Phosphor Bronze	Tin-plated	10,000pcs

5106-T (2.00mm pitch crimp terminal)

Reference Informations:

*Used in 5106 series Housing

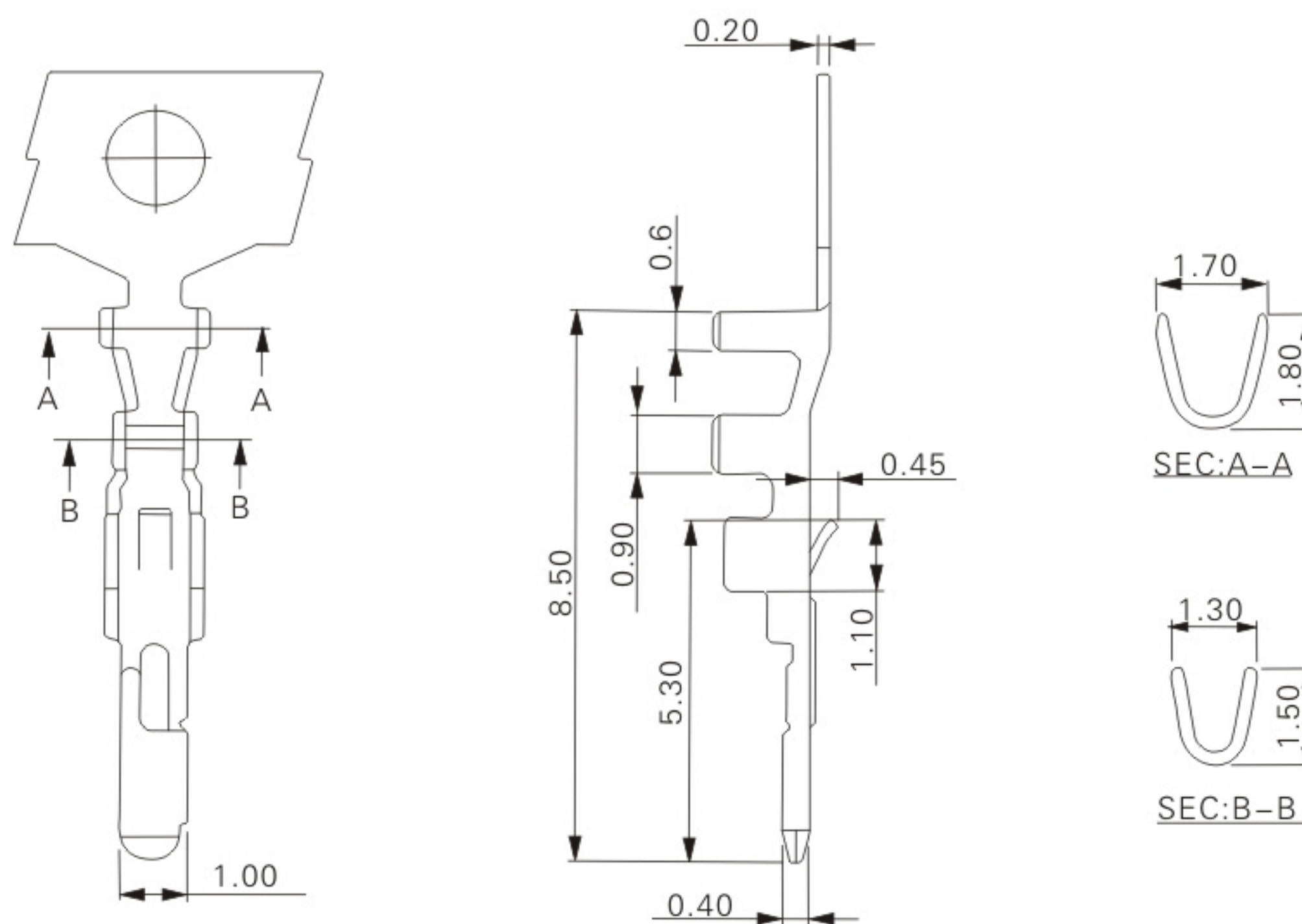

Ordering Information & Specifications

Unit: mm

Part No.	Wire Range	Insulation O.D.	Material	Finish	Qty/reel
5106P	AWG#24-#28	1.40mm(max)	Phosphor Bronze	Tin-plated	10,000pcs

5105H-NP (2.00mm pitch crimp housing)

Reference Informations:

- *Material:Nylon 66,UL 94V-0
Halogen Free:Nylon 66,UL94V-0
- *Suitable 5105-T series Terminal
- *Mates with 5106H series Housing

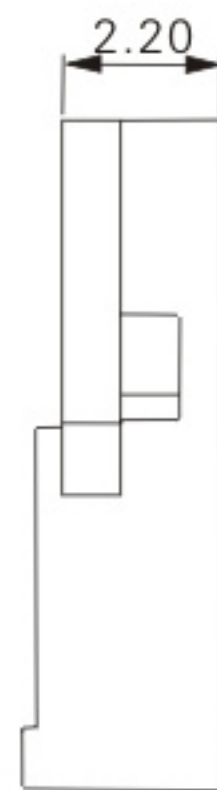
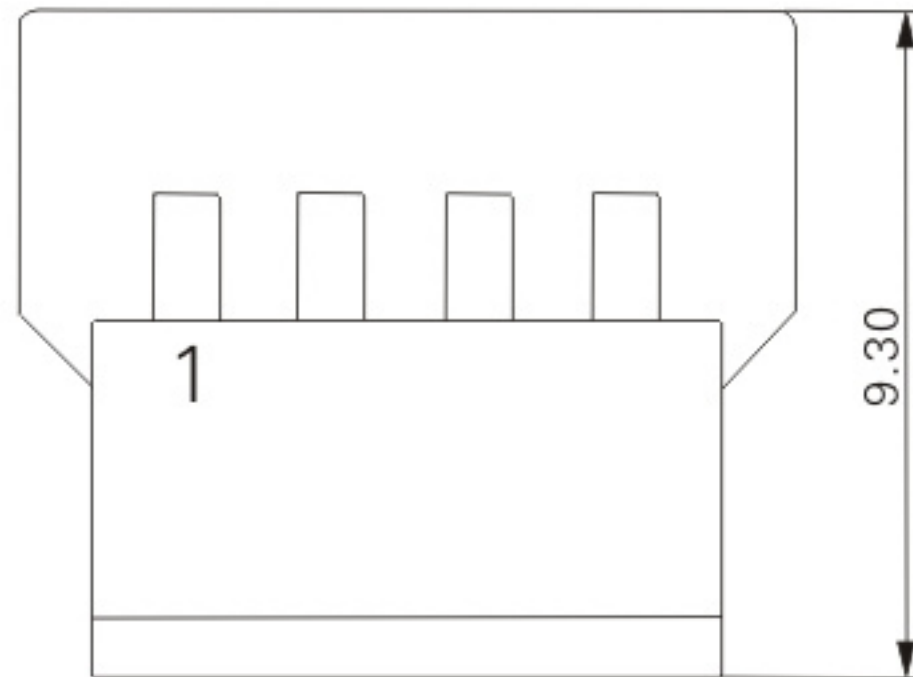
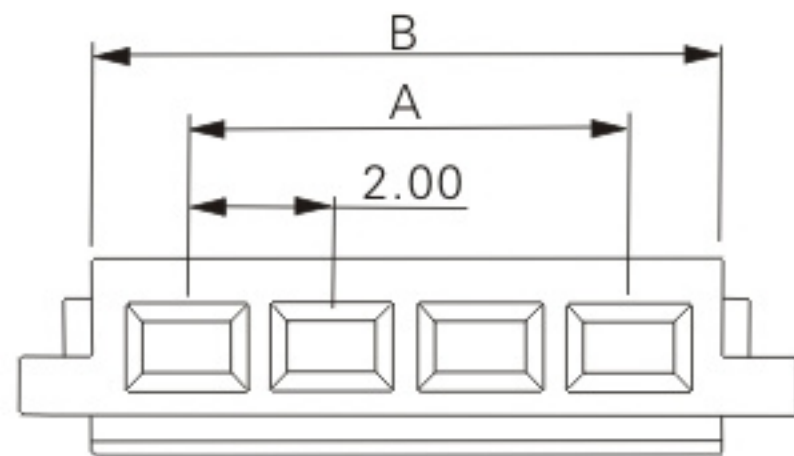
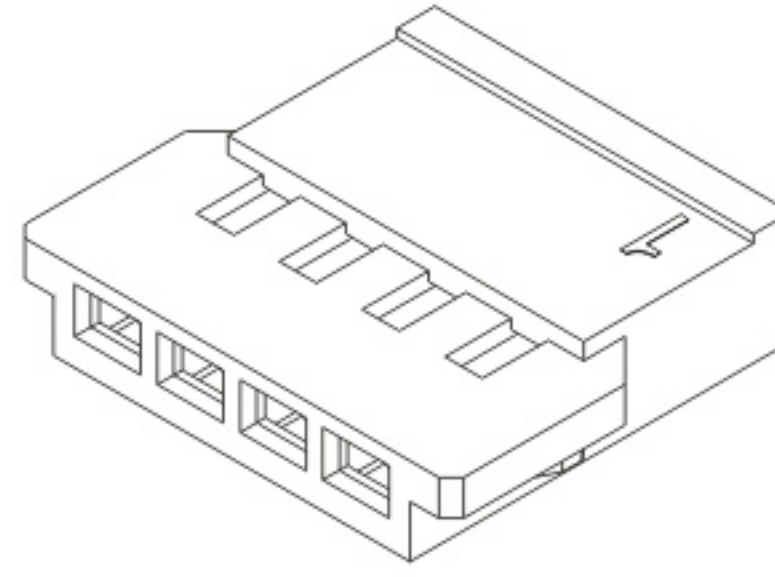

Ordering Information & Dimensions

Circuits	Part No.	DIM.(mm)	
		A	B
02	5105H-02P	2.0	4.60
03	5105H-03P	4.0	6.60
04	5105H-04P	6.0	8.60
05	5105H-05P	8.0	10.60
06	5105H-06P	10.0	12.60
07	5105H-07P	12.0	14.60
08	5105H-08P	14.0	16.60
09	5105H-09P	16.0	18.60
10	5105H-10P	18.0	20.60
11	5105H-11P	20.0	22.60
12	5105H-12P	22.0	24.60
13	5105H-13P	24.0	26.60
14	5105H-14P	26.0	28.60
15	5105H-15P	28.0	30.60
16	5105H-16P	30.0	32.60

5106H-NP (2.00mm pitch crimp housing)

Reference Informations:

- *Material:Nylon66,UL94V-0
Halogen Free:Nylon 66,UL94V-0
- *Suitable 5106-T series Terminal
- *Mates with 5105H series Housing

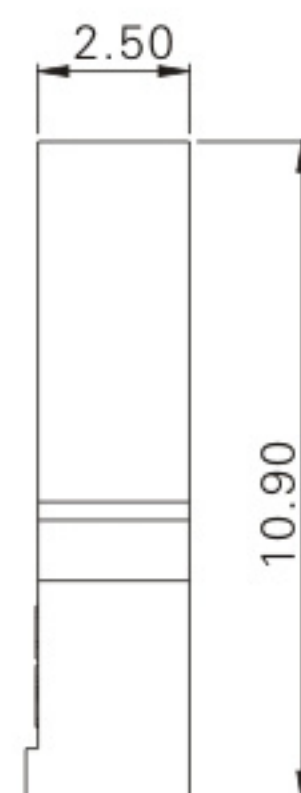
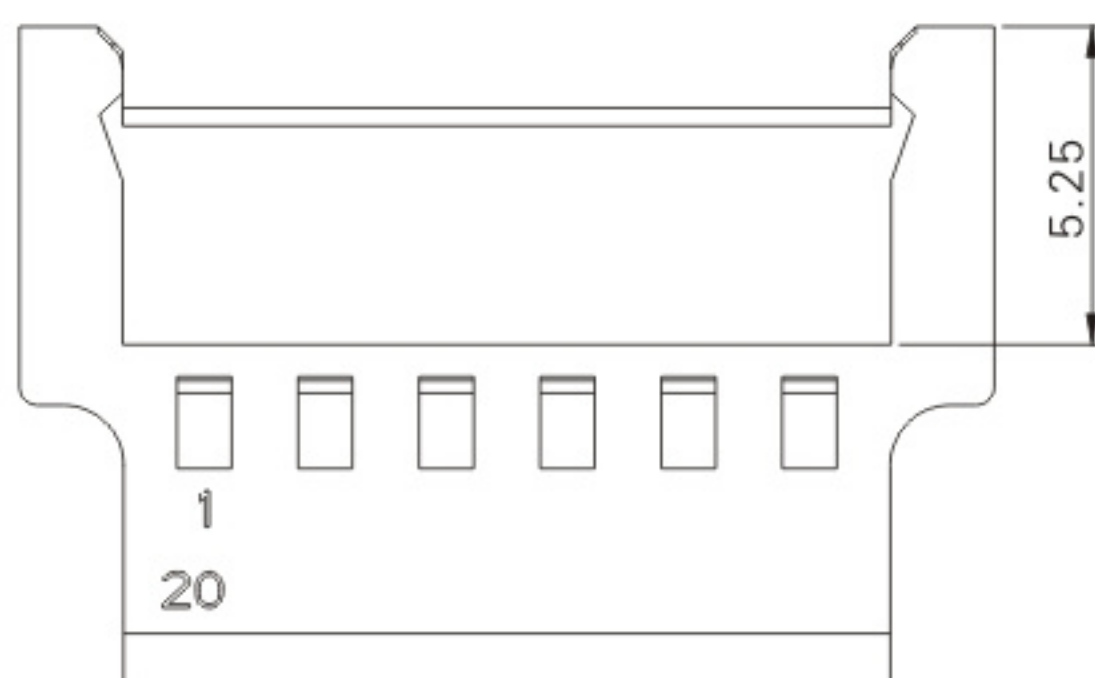
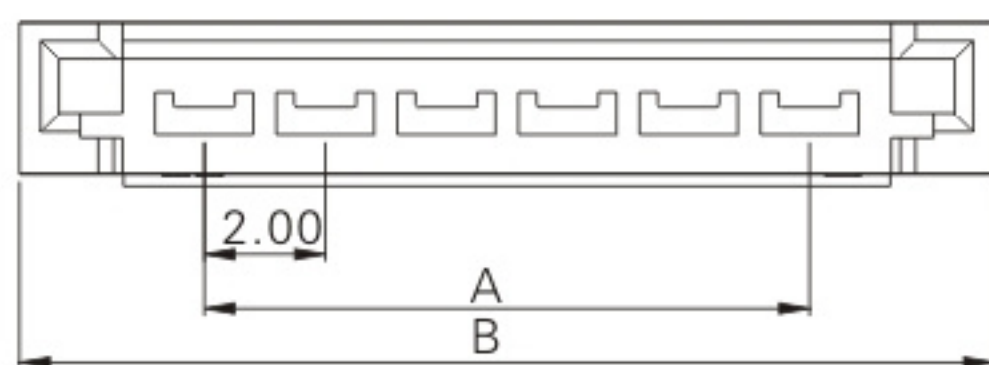
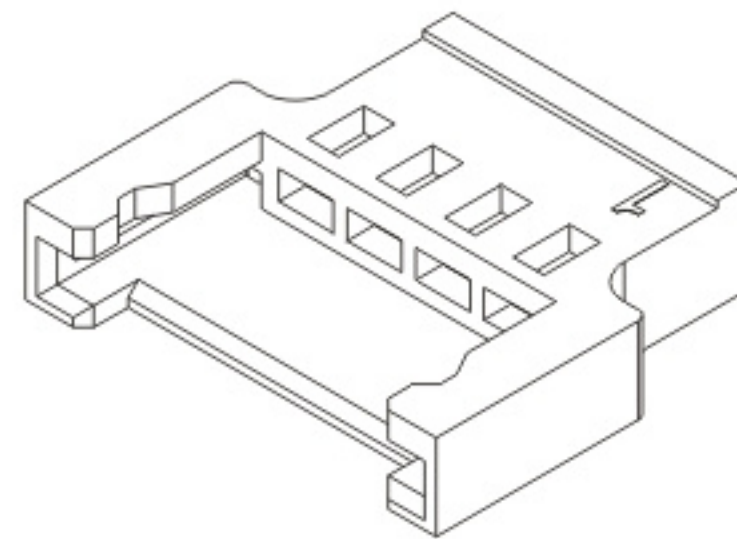

Ordering Information & Dimensions

Circuits	Part No.	DIM.(mm)	
		A	B
02	5106H-02P	2.0	8.10
03	5106H-03P	4.0	10.10
04	5106H-04P	6.0	12.10
05	5106H-05P	8.0	14.10
06	5106H-06P	10.0	16.10
07	5106H-07P	12.0	18.10
08	5106H-08P	14.0	20.10
09	5106H-09P	16.0	22.10
10	5106H-10P	18.0	24.10
11	5106H-11P	20.0	26.10
12	5106H-12P	22.0	28.10
13	5106H-13P	24.0	30.10
14	5106H-14P	26.0	32.10
15	5106H-15P	28.0	34.10
16	5106H-16P	30.0	36.10